

CM-V-1 型 隔 振 器 安 装 使 用 说 明

Method of Installation & Adjustment
For CM-V-1 Resilient Mounting



无锡齐耀华东隔振科技有限公司
WUXI QIYAO HUADONG VIBRATION ISOLATION TECHNOLOGIES CO., LTD

1 CM-V-1 型隔振器的安装调整 **Installation and adjustment of CM-V-1 type vibration isolator**

CM-V-1 型隔振器[附图 (1)]的理想支承状态, 应该是每个隔振器承受相同的载荷, 在使用中应使每个隔振器在其垂直承载方向的变形量尽量相同。为了达到这一要求, 可以通过在每个隔振器下分别配制适当厚度的调整垫块来实现, 其具体方法可如下:

Ideal support condition of CM-V-1 type vibration isolator [Fig (1)] requires the load evenly distributed on each and make vertical deformation of each vibration isolator as close as possible. Practically, adjust the appropriate thickness of the adjustment pad in each vibration isolator can make it possible.

1.1 安装调整的准备。 **Pre - adjustment preparation**

1.1.1 拆除隔振器顶部的防油帽①、螺母②和垫圈③。

Remove oil caps①, nut② and washer③.

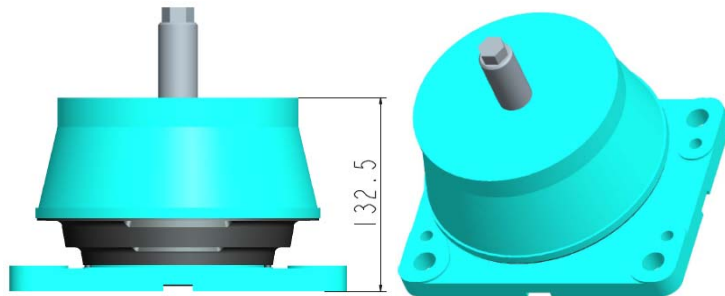

1.1.2 用液压千斤顶或起重设备升高被隔振的柴油机组公共底座, 使公共底座上隔振器安装面距基座上隔振器安装面约 250mm, 并尽量保持公共底座水平。然后将各个隔振器置放于隔振布置计算确定的具体位置, 并用螺母将隔振器与公共底座相连接。

Hoist the public base of diesel with hydraulic jacks or crane and make the fitting surfaces of public base and foundation apart by 250mm. Level the public base. Put vibration isolators on assigned places and attach the undersurfaces of the vibration isolators to the vessel's foundation via shims with nuts.

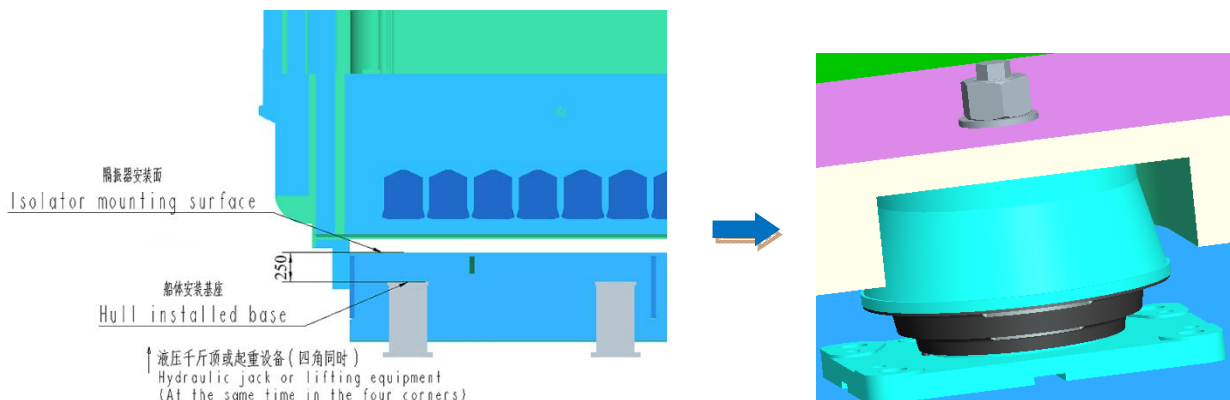

1.1.3 在每个隔振器下座板⑧的4个M12螺孔中旋入4个M12×100的顶起螺栓，并使该螺栓伸出下座板下平面至少40mm，每个隔振器应一致。

Screw in four M12×100 bolts in the screw hole of the lower plate⑧ of each vibration isolator. And hold the bolt out of the lower plane at least 40mm. Each vibration isolator should be consistent.

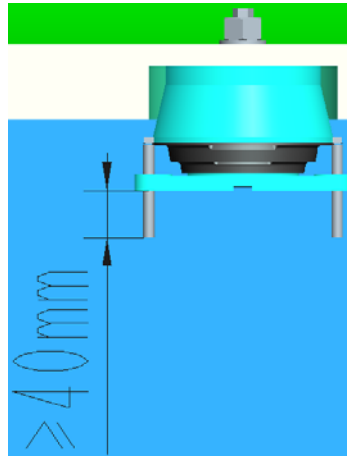

1.1.4 慢慢放下被隔振的柴油发电机组公共底座，使其全部重量通过各个隔振器及其M12顶起螺栓坐落在基座面板上，检查确认每个M12顶起螺栓均坐实。

Vibration isolation of diesel generating sets down slowly by public base, make its full weight through various vibration isolator and its M12 jacking bolts is located on the base panel, check each M12 jacking bolts are filled.

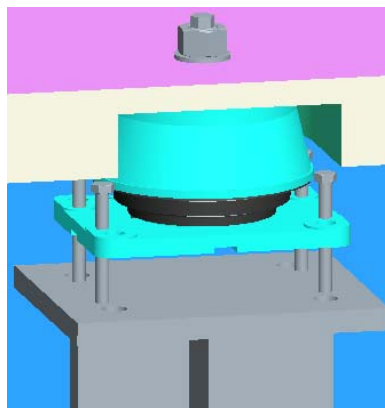

1.1.5 检查每个隔振器的缓冲限位螺栓⑦，确认其能自由旋转。否则应调整M12顶起螺栓，直至缓冲限位螺栓能自由旋转为止。

Check all the internal buffers⑦ in order to ensure that they can revolve freely. Otherwise, the M12 jacking bolts should be adjusted until the internal buffers⑦ are free to move.

1.1.6 在此状态下，使隔振器压载48小时。

Keep such state for 48 hours.

1.2 调整垫块的配置 **Configure the adjusting block**

1.2.1 压载48小时后，为了达到各个隔振器承载均匀的要求，应在每个隔振器四个角的部位，测量隔振器的实际承载高度 H_n ，并使每个隔振器的实际承载高度尺寸，与所有隔振器平均承载高度尺寸之间的偏差值尽可能小，最大不超

过±1mm。若未达到，则应先从最大偏差的那个隔振器开始，通过调节 M12 顶起螺栓的高度来调整隔振器的承载高度 H_n ，直到达到要求为止并尽量保持公共底座水平。

Ballast after 48 hours, in order to achieve various vibration isolator load-bearing uniform requirements, should be in the area of each vibration isolator four corners, the measurement of vibration isolator of the actual bearing height H_n , and should make each vibration isolator actual bearing height size, and all of the vibration isolator bearing size deviation between the average value as small as possible, most not more than plus or minus 1 mm. If did not meet, it should be from the biggest deviation of the vibration isolator, by adjusting the M12 jacking bolts of vibration isolator to adjust the height of the bearing height, until meet the requirements and try to keep the public base level.

$$\text{平均承载高度} = \frac{\text{各个隔振器承载高度之和}}{\text{承载的隔振器数量}} = \frac{H_1 + H_2 + \dots + H_n}{N}$$

$$\text{Mean bearing height} = \frac{\text{The sum of the bearing height of each isolator}}{\text{Number of vibration isolators}} = \frac{H_1 + H_2 + \dots + H_n}{N}$$

1.2.2 完成上述步骤后，方可测量每个隔振器的下座板与基座面板之间的距离尺寸（即 M12×100 顶起螺栓的顶起高度）。在测量中，应对每个隔振器四个角均测量。测得的最大值，确定为调整垫块的厚度尺寸。

After completing the above steps, just can measure each vibration isolator under the plate and the distance between the base panel size(That is jacking height of M12×100 Jacking bolts). In the measurement, the four angles of each isolator were measured. The maximum measured value is the thickness of the size of the adjusting block.

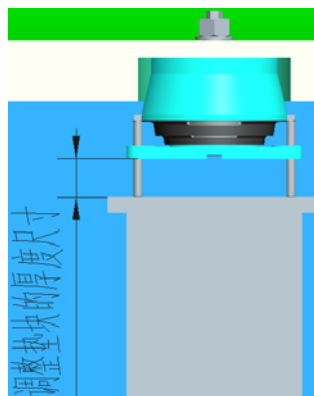

1.2.3 为了隔振器的拆换方便，每个隔振器调整垫块的厚度应不小于40mm，其面积略大于隔振器下座板的面积。按照隔振器下座板4-φ18的通孔位置尺寸对调整垫块划线打孔，并与相应的隔振器一起编号、打上标记。

To facilitate the replacement of the vibration isolator, the thickness of each vibration isolator should not be less than 40mm. Its area is slightly larger than the area of the plate under the vibration isolator. According to the position size of 4-φ18 of the vibration isolator, the alignment of the adjusting pad is drilled. And the corresponding vibration isolator is numbered and marked.

1.3 调整垫块的安装 Install the adjustment block

1.3.1 逆时针旋转内置的缓冲限位螺栓⑦，直至内部螺栓头与隔振器下座板接触。

Counterclockwise rotation built-in internal buffer⑦, until the internal bolt head is in contact with the diaphragm.

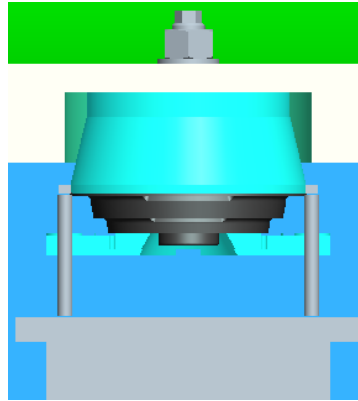

1.3.2 用液压千斤顶或起重设备将隔振器的柴油发电机组公共底座缓慢升高，直到M12×100的顶起螺栓全部离开基座面板，拆除所有的M12×100的顶起螺栓。

Hoist the public base of diesel with hydraulic jacks or crane, until the M12×100 Jacking bolts is bolted out of the base panel. Remove all of the M12×100 Jacking bolts.

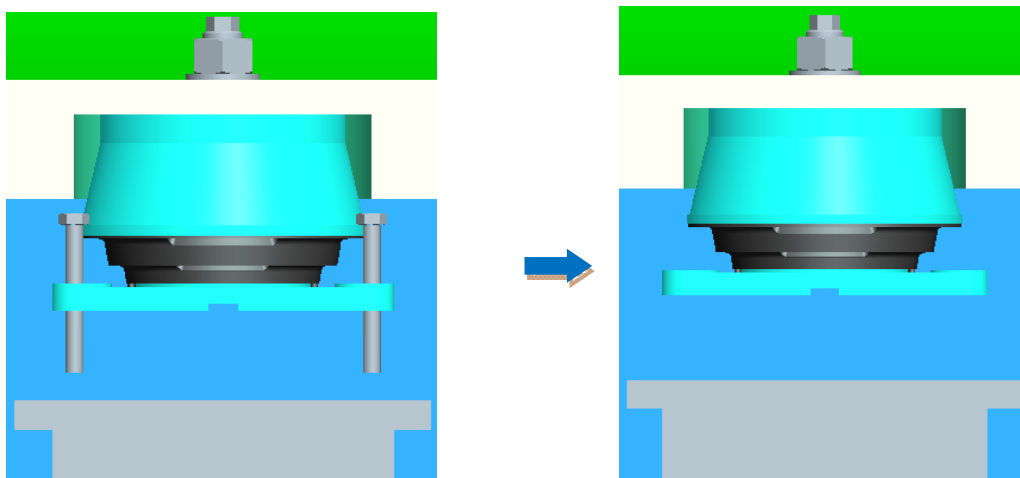

1.3.3 根据各个隔振器编号，将相应的调整垫块置于各个隔振器下的基座面板上，对准各安装螺栓孔的位置后逐渐放下隔振器的柴油发电机组公共底座，直至载荷完全作用在调整垫块上，并及时上紧所有隔振器下座板⑧的安装固定螺栓。

According to the oscillator number, place the corresponding adjustment block on the base panel under the individual vibration isolator. Align the position of each mounting bolt hole and then gradually put down the common base of the diesel generator set. Until the load is fully applied to the adjustment block. And tighten the mounting bolts of the mounting plate⑧ in time

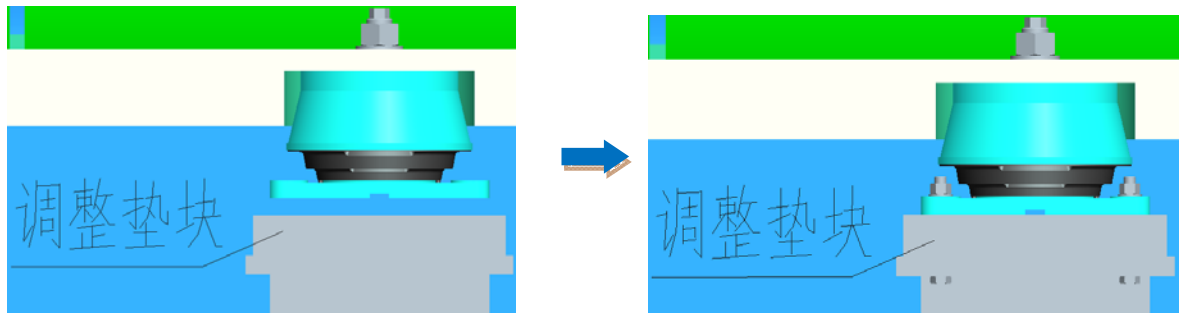

2 缓冲限位螺栓的调整和锁紧 Adjustments and tightening of internal buffer

2.1 隔振器安装完成后，应及时调整缓冲限位螺栓⑦的缓冲限位间隙。先顺时针方向旋转缓冲限位螺栓⑦，直至内部螺栓头接触到调整垫块。然后逆时针方向旋转缓冲限位螺栓⑦，直至内部螺栓头接触到隔振器下座板⑧。如此反复两次，应确认每次旋转应有四整圈，并且能自由旋转，这时螺栓头应接触调整垫块。

Having installed isolators, adjust limit-stop clearance of internal buffer⑦. Revolve internal buffer⑦ clockwise first, until it contacts adjusting block. Then revolve internal buffer⑦ counter-clockwise, until bolt head contacts base casting⑧. Repeat, and be sure each revolution comprises of 4 cycles. Internal buffer shall be able to move freely. Though bolt head shall contact adjusting block then.

2.2 完成上述步骤后，即可顺时针方向旋转缓冲限位螺栓约 2 圈，并用厚 4mm 的厚度塞规，从隔振器下座板⑧中间的槽孔中检测缓冲限位螺栓头与调整垫块之间的间隙，以确认没有接触。

Finish these procedures, turn the internal buffer 2 turns clockwise and check with a feeler gauge of 4mm thick between bolt head and adjusting block through slot on base casting⑧. Be sure there is no contact.

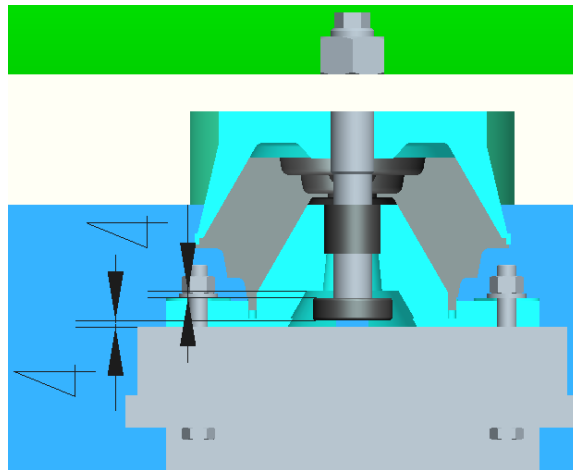

2.3 旋紧螺母②和垫圈③，以锁紧缓冲限位螺栓⑦，最后再盖上防油帽①。

Tighten the nut②and the gasket③. Tighten the internal buffer⑦. Finally add oil cap①.

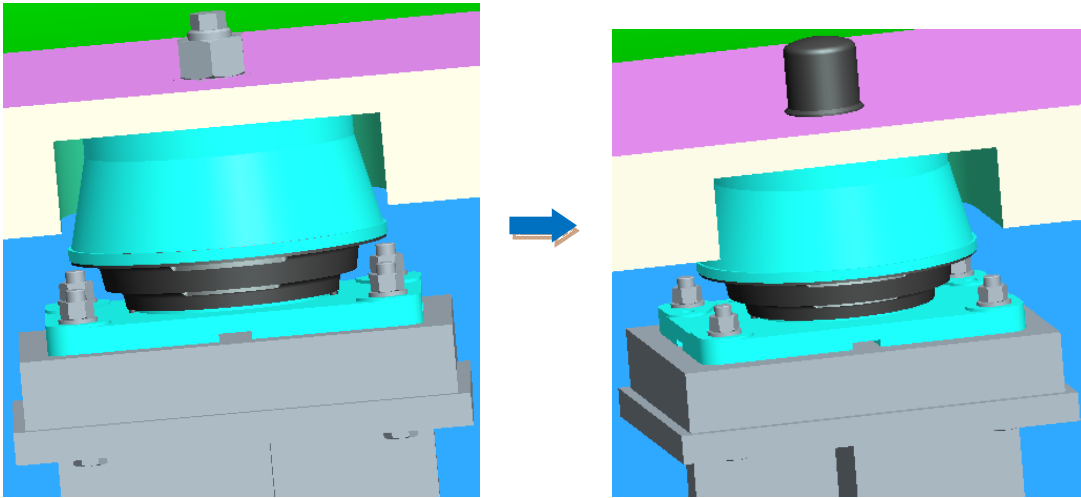

2.4 上紧所有螺栓和螺母，并确认安装无误。（图中柴油机仅为示意图）

Tighten all bolts and nuts and check the installation procedure. (The figure in the diesel engine is only sketch.)

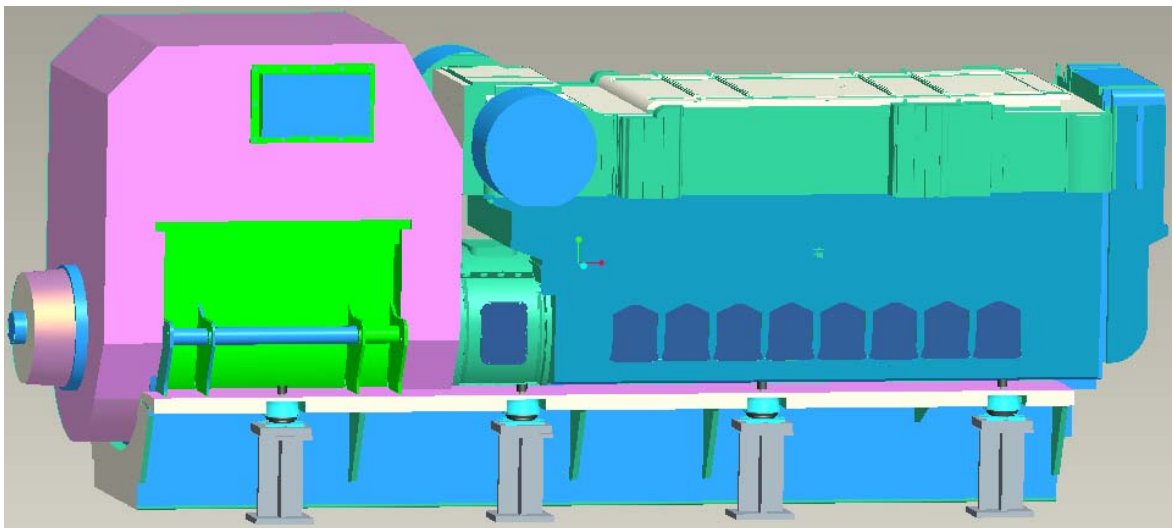

3 CM-V-1 型隔振器的更换 Replacement of CM-V-1 type vibration isolator

3.1 一般情况下，隔振器在正常承载下静变形均为大于 4mm。在升高柴油机机脚前，首先要顺时针方向旋转缓冲限位螺栓⑦，直至内部螺栓头接触到调整垫块。当隔振器卸除载荷时，橡胶回弹，隔振器自由高度加大。要缓慢升高柴油机机脚，同时确保缓冲限位螺栓时刻保持自由旋动。否则，隔振器会通过缓冲限位螺栓将上、下座板锁死，无法现场更换损坏的橡胶部件。

Under normal circumstances, the vibration isolator under normal load bearing static deformation are all greater than 4 mm. Raise the feet of diesel, the first to revolve internal buffer⑦ clockwise, until it contacts adjusting block. When vibration isolator removable load, rubber rebound, vibration isolator free height increase.

free vibration isolator is highly increased. Slowly increase the feet of diesel, at the same time to ensure the safety internal buffer keep free of gyration. Otherwise, the vibration isolator will pass the safety internal buffer the top casting and base casting, unable to field replacement damage of rubber parts.

3.2 拆除所有隔振器下座板⑧的螺栓，升高柴油发电机组的公共底座，以便调整垫块和隔振器能自由抽出。

Remove the bolt from the the plate⑧. Raise the public base of the diesel generator in order to the adjusting block and vibration isolator are free to extract.

3.3 由于 CM-V-1 型隔振器为全装配式隔振器，更换时只需要更换损坏的部件（通常为橡胶元件，如防油帽①、锥形减振圈⑤等等）即可。

CM-V-1 type vibration isolator is assembled mounting. You only need to replace broken parts (normally elastic parts as oil cap①, resilient mounting⑤ and etc.)

3.4 换上新的隔振器，放下柴油发电机组的公共底。并按 1 和 2 节的规程调整垫块以及调整缓冲限位螺栓的间隙。

Install new isolators, then lower public base of diesel. Adjust adjustment block and internal buffers as 1 & 2 described.

3.5 上紧所有螺栓和螺母，并确认更换安装无误。

Tighten all bolts and nuts and check the installation procedure.

4 CM-V-1 型隔振器的维护检查 **Maintenance of CM-V-1 type vibration isolator**

CM-V-1 型隔振器在使用中的维护检查可分为外观的维护检查和缓冲限位间隙的检查。

Maintenance of CM-V-1 type vibration isolator in use can be divided into appearance checkup and internal buffer clearance checkup.

4.1 外观的维护检查 **Appearance checkup**

4.1.1 隔振器的橡胶元件应避免油渍粘污和油水浸泡。若遇有油渍粘污和油水浸泡后，应及时清除油污并将橡胶表面擦拭清洁。

Rubber parts of the isolator shall avoid oil stain and soak. If stained or soaked, remove the oil stain and clean the rubber appearance.

4.1.2 隔振器的安装固定螺栓和螺母应经常进行检查，若有松动应及时旋紧。

Check fixing bolts and nuts of the isolator often. Tighten them if loosen.

4.1.3 隔振器锥形减振圈⑤的橡胶元件表面，若有划痕、龟裂、脱胶等现象发生，应及时更换。

Surface of resilient mounting⑤ shall be replaced if scratch, flaw or ungluing found on it.

4.2 缓冲限位间隙的检查 **Internal buffer clearance checkup**

4.2.1 应定期(一般为 6 个月)对所有隔振器的缓冲限位间隙进行检查。若有不合格, 则应进行缓冲限位间隙调整。

Should be regularly (usually for 6 months) check the internal buffer clearance of all vibration isolator. If disqualified, adjust the clearance.

4.2.2 凡是更换了新的隔振器或受到非正常的外力作用之后, 均应使用厚 4mm 的厚度塞规, 对所有隔振器的缓冲限位间隙进行检查。若有不合格, 则应进行缓冲限位间隙调整。

Newly replaced isolator, or abnormal shock found, 4mm thick feeler gauge shall be used to check the internal buffer clearance. If disqualified, adjust the clearance.

4.2.3 调整方法同 2.2 条及 2.3 条的内容。

Referring to item 2.2 & 2.3.

附图 (1) CM-V-1 型隔振器

Fig (1) CM-V-1 type vibration isolator

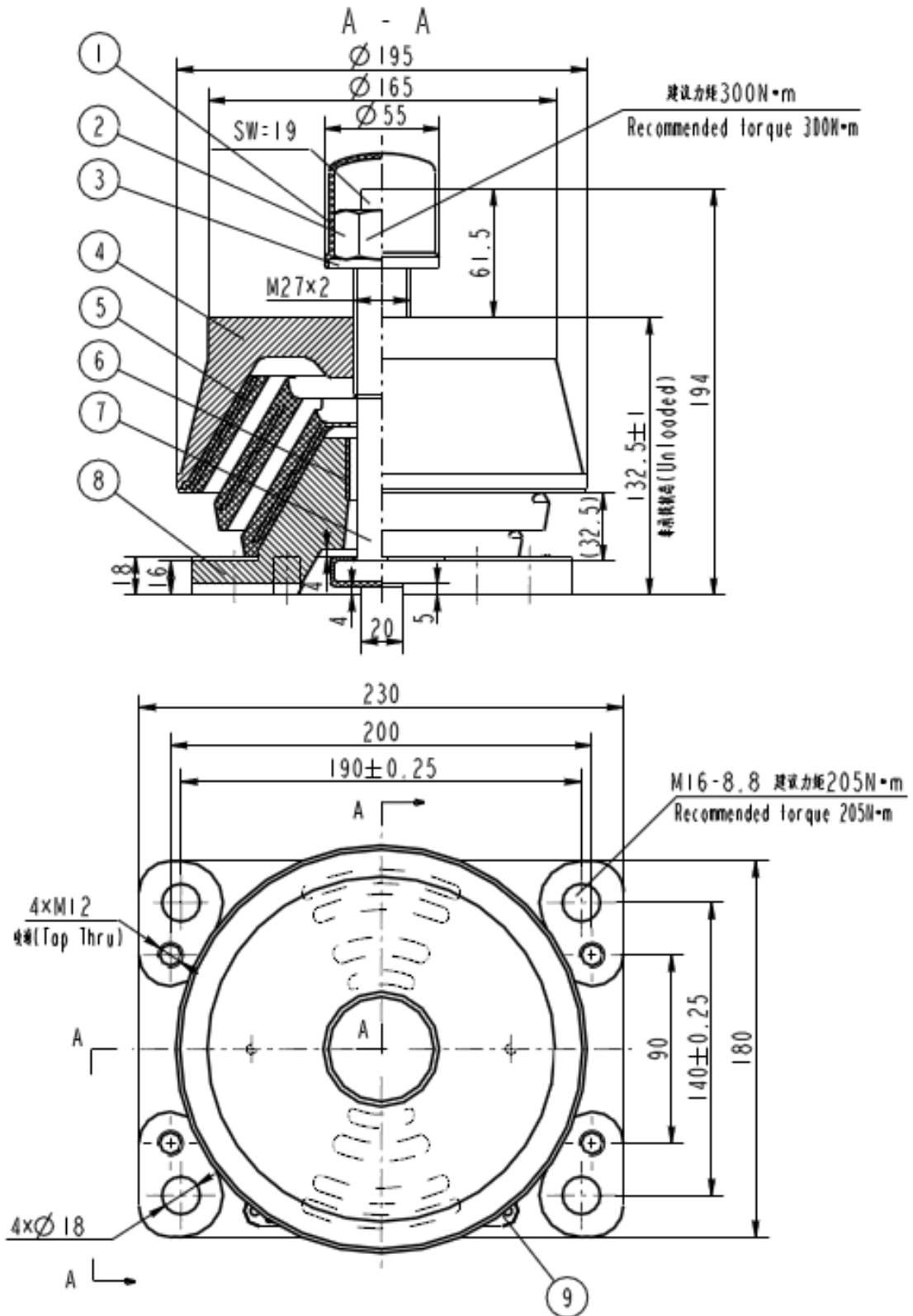

- 1、防油帽 Oil Cap； 2、螺母 Nut； 3、垫圈 Washer； 4、上座板 Top Casting；
5、锥形减振圈 Resilient Mounting； 6、橡胶圈 Rubber Coil； 7、缓冲限位螺栓 Internal Buffer；
8、下座板 Base Casting； 9、铭牌 Name Plate。