

CM-VII型 隔振器 安装使用说明

Method of Installation & Adjustment
For CM-VII Resilient Mounting



无锡齐耀华东隔振科技有限公司
WUXI QIYAO HUADONG VIBRATION ISOLATION TECHNOLOGIES CO., LTD

1 CM-VII型隔振器的安装调整 Installation and adjustment of CM-VII type vibration isolator

CM-VII型隔振器[附图(1)]的理想支承状态,应该是每个隔振器承受相同的载荷,在使用中应使每个隔振器在其垂直承载方向的变形量尽量相同。为了达到这一要求,可以通过调整每个隔振器上的调节螺母①来实现,其具体方法可如下:

Ideal support condition of CM-VII type vibration isolator [Fig (1)] requires the load evenly distributed on each and make vertical deformation of each vibration isolator as close as possible. Practically, adjust the nut① of the vibration isolator can make it possible.

1.1 安装前将全部隔振器的调节螺母①均旋至最低处,同时拆除隔振器顶部的保护帽⑨、螺母⑧和垫圈⑦。

Before installation, revolve all the nuts① to the lowest place and remove protective caps⑨, nuts⑧ and washers⑦.

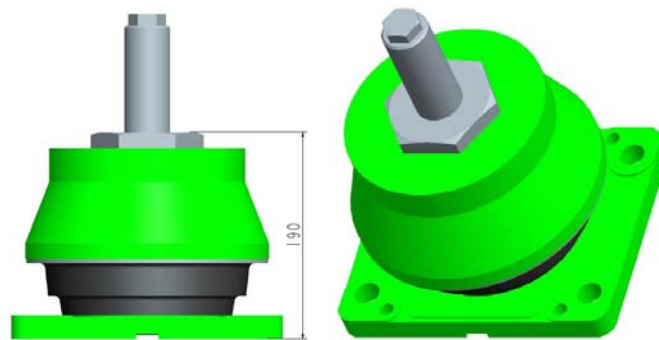

1.2 用液压千斤顶或起重设备升高被隔振的柴油机机脚,使柴油机机脚上隔振器安装面距安装基座上隔振器安装面约250mm,并尽量保持柴油机水平。然后将各个隔振器置放于隔振布置计算确定的具体位置,并用螺母将隔振器与安装基座连接紧固。

Hoist the feet of diesel with hydraulic jacks or crane and make the fitting surfaces of feet and foundation apart by 250mm. Level the diesel. Put vibration isolators on assigned places and attach the undersurfaces of the vibration isolators to the vessel's foundation via shims with bolts.

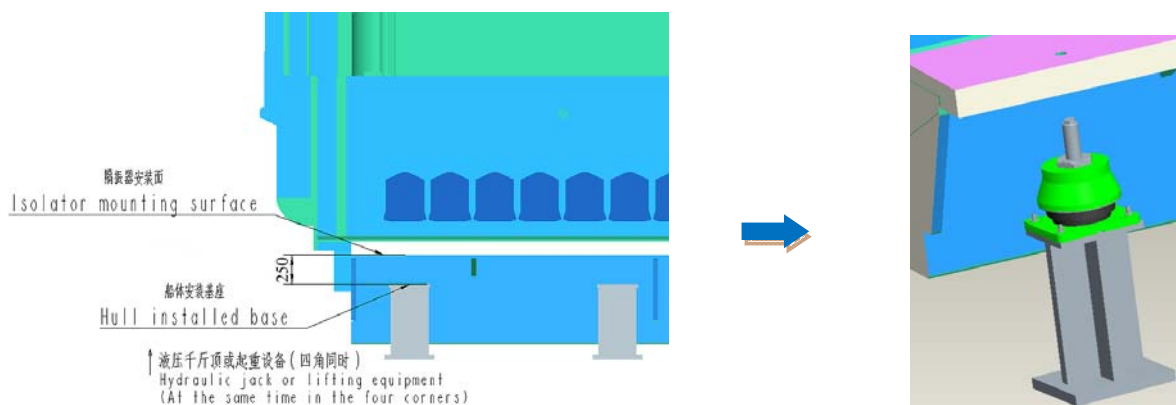

1.3 缓慢放下被隔振的柴油机，使隔振器的缓冲限位螺栓⑤全部穿过柴油机机脚上的安装孔。在保持机体水平的前提下，使隔振器上安装面（即调节螺母①上表面）与机体安装孔下表面的间隙值不要超过 10mm。（该间隙可以根据轴系对中要求具体调整）

Lower the diesel gently until the whole internal buffers⑤ are threaded through holes of the diesel feet. Level the diesel and make the clearances between the upper surfaces of the isolators (i.e. the upper surfaces of adjusting nuts①) and the undersurfaces of the holes be less than 10mm.(The clearance can be adjusted according to the alignment of shafting)

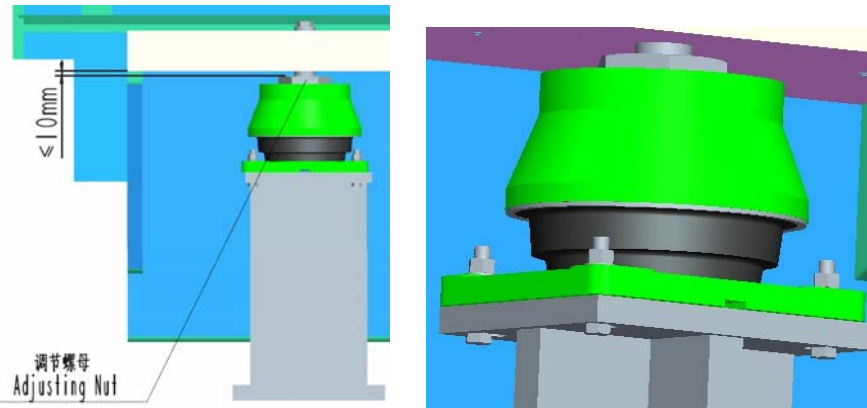

1.4 旋动隔振器的调节螺母①，使调节螺母①上表面全部与柴油机机脚上的安装孔下表面贴合紧密。

Revolve adjusting nuts① and make the upper surfaces of nuts① fit the undersurfaces of the holes of the diesel feet .

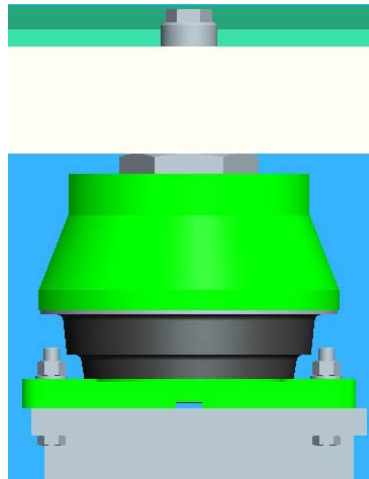

1.5 检查每个隔振器的缓冲限位螺栓⑤，确认其能自由转动。

Check all the internal buffers⑤ in order to ensure that they can revolve freely.

1.6 缓慢放下柴油机，使其全部重量通过各个隔振器坐落在安装基座面板上，并保证每个隔振器的缓冲限位螺栓⑤仍能自由转动。

Lower the diesel gently until it rests completely on the foundation and check to make sure that all internal buffers⑤ can revolve freely.

1.7 在此状态下，使隔振器压载 48 小时。

Keep such state for 48 hours.

1.8 压载 48 小时后，借助液压千斤顶或起重设备使柴油机保持水平，同时检查全部隔振器的调节螺母①是否仍与柴油发电机组公共底座贴合紧密？否则，应立即调整至贴合紧密。此时，隔振器安装即完成。

Loaded for 48 hours, level the diesel with hydraulic jack or crane, adjust all nuts① and ensure that they fit the foundation of the diesel, and then installation of isolators is completed.

2 缓冲限位螺栓的调整和锁紧 **Adjustments and tightening of internal buffer**

2.1 隔振器安装完成后，应及时调整缓冲限位螺栓⑤的缓冲限位间隙。先顺时针方向旋转缓冲限位螺栓⑤，直至内部螺栓头接触到安装基座面板。然后逆时针方向旋转缓冲限位螺栓⑤，直至内部螺栓头接触到隔振器下座板④。如此反复两次，应确认每次旋转应有四整圈，并且能自由旋转，这时螺栓头应接触安装基座面板。

Having installed isolators, adjust limit-stop clearance of internal buffer⑤. Revolve internal buffer⑤ clockwise first, until it contacts shim. Then revolve internal buffer⑤ counter-clockwise, until bolt head contacts base casting④. Repeat, and be sure each revolution comprises of 4 cycles. Internal buffer shall be able to move freely. Though bolt head shall contact shim then.

2.2 完成上述步骤后，即可顺时针方向旋转缓冲限位螺栓约 2 圈，并用厚 4mm 的厚度塞规，从隔振器下座板④中间的槽孔中检测缓冲限位螺栓头与安装基座面板之间的间隙，以确认没有接触。

Finish these procedures, turn the internal buffer 2 turns clockwise and check with a feeler gauge of 4mm thick between bolt head and shim through slot on base casting④. Be sure there is no contact.

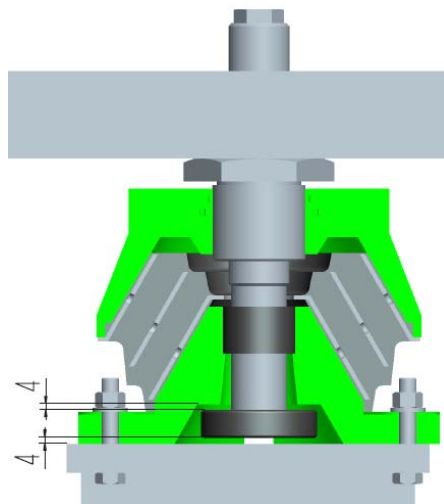

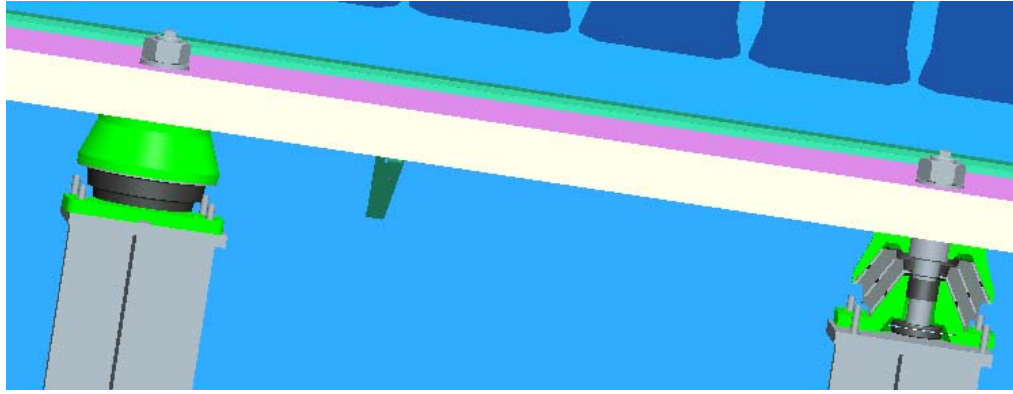

2.3 旋紧螺母⑧和垫圈⑦，以锁紧缓冲限位螺栓⑤，最后再盖上保护帽⑨。

Tighten nut⑧ and washer⑦ to lock internal buffer⑤. Finally add protective cap⑨.

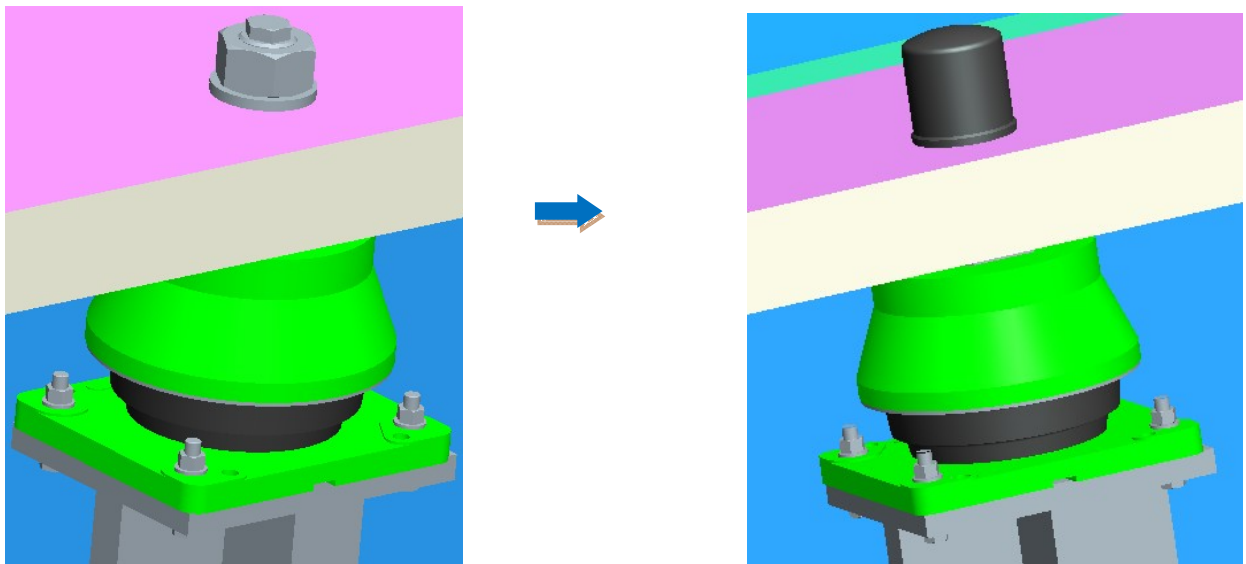

2.4 上紧所有螺栓和螺母，并确认安装无误。（图中柴油机仅为示意图）

Tighten all bolts and nuts and check the installation procedure. (The figure in the diesel engine is only sketch.)

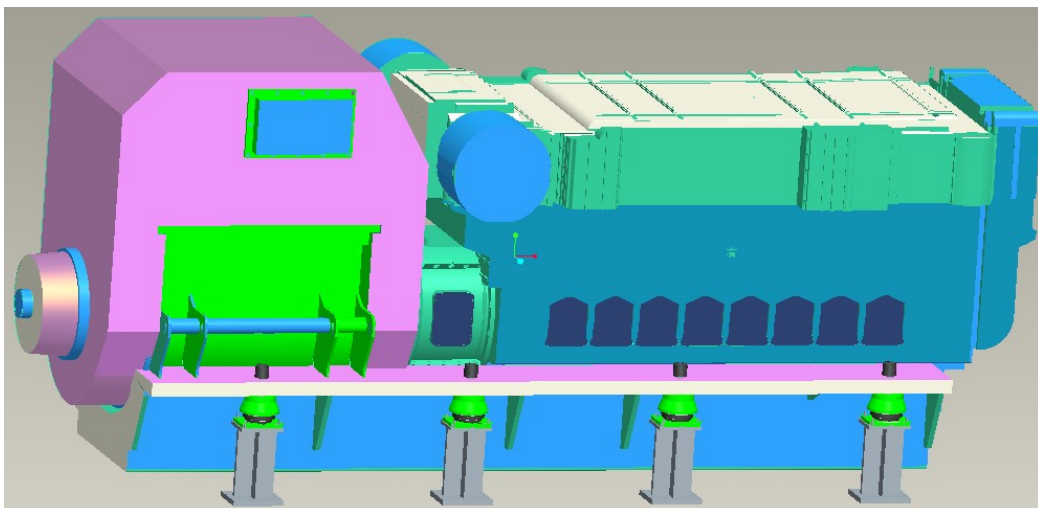

3 CM-VII型隔振器的更换 **Replacement of CM-VII type vibration isolator**

3.1 一般情况下，隔振器在正常承载下静变形均为大于 4mm。在升高柴油机机脚前，首先要顺时针方向旋转缓冲限位螺栓⑤，直至内部螺栓头接触到船体安装基座面板。当隔振器卸除载荷时，橡胶回弹，隔振器自由高度加大。要缓慢升高柴油机机脚，同时确保缓冲限位螺栓时刻保持自由旋动。否则，隔振器会通过缓冲限位螺栓将上、下座板锁死，无法现场更换损坏的橡胶部件。

Under normal circumstances, the vibration isolator under normal load bearing static deformation are all greater than 4 mm. Raise the feet of diesel, the first to revolve internal buffer⑤ clockwise, until it contacts shim. When vibration isolator removable load, rubber rebound, free vibration isolator is highly increased. Slowly increase the feet of diesel, at the same time to ensure the safety internal buffer keep free of gyration. Otherwise, the vibration isolator will pass the safety internal buffer the top casting and base casting, unable to field replacement damage of rubber parts.

3.2 拆除所有隔振器下座板④的螺栓，借助液压千斤顶或起重设备缓慢升高柴油机机脚，以便隔振器能自由抽出。

Remove all base casting④ bolts of isolator ,and raise feet of diesel with hydraulic jack or crane to take out isolators freely.

3.3 由于 CM-VII型隔振器为全装配式隔振器，更换时只需要更换损坏的部件（通常为橡胶元件，如保护帽⑨、锥形减振圈③等等）即可。

CM-VII type vibration isolator is assembled mounting. You only need to replace broken parts (normally elastic parts as protective cap⑨, resilient mounting③ and etc.)

3.4 换上新的隔振器，放下柴油机机脚，并按 1 和 2 节的规程调整调节螺母①的位置以及调整缓冲限位螺栓的间隙。

Install new isolators, then lower feet of diesel. Adjust nuts① and internal buffers as 1 & 2 described.

3.5 上紧所有螺栓和螺母，并确认更换安装无误。

Tighten all bolts and nuts and check the installation procedure.

4 CM-VII型隔振器的维护检查 **Maintenance of CM-VII type vibration isolator**

CM-VII型隔振器在使用中的维护检查可分为外观的维护检查和缓冲限位间隙的检查。

Maintenance of CM-VII type vibration isolator in use can be divided into appearance checkup and internal buffer clearance checkup.

4.1 外观的维护检查 **Appearance checkup**

4.1.1 隔振器的橡胶元件应避免油渍粘污和油水浸泡。若遇有油渍粘污和油水

浸泡后，应及时清除油污并将橡胶表面擦拭清洁。

Rubber parts of the isolator shall avoid oil stain and soak. If stained or soaked, remove the oil stain and clean the rubber appearance.

4.1.2 隔振器的安装固定螺栓和螺母应经常进行检查，若有松动应及时旋紧。

Check fixing bolts and nuts of the isolator often. Tighten them if loosen.

4.1.3 隔振器锥形减振圈③的橡胶元件表面，若有划痕、龟裂、脱胶等现象发生，应及时更换。

Surface of resilient mounting③ shall be replaced if scratch, flaw or ungluing found on it.

4.2 缓冲限位间隙的检查 **Internal buffer clearance checkup**

4.2.1 应定期(一般为 6 个月)对所有隔振器的缓冲限位间隙进行检查。若有不合格，则应进行缓冲限位间隙调整。

Should be regularly (usually for 6 months) check the internal buffer clearance of all vibration isolator. If disqualified, adjust the clearance.

4.2.2 凡是更换了新的隔振器或受到非正常的外力作用之后，均应使用厚 4mm 的厚度塞规，对所有隔振器的缓冲限位间隙进行检查。若有不合格，则应进行缓冲限位间隙调整。

Newly replaced isolator, or abnormal shock found, 4mm thick feeler gauge shall be used to check the internal buffer clearance. If disqualified, adjust the clearance.

4.2.3 调整方法同 2.2 条及 2.3 条的内容。

Referring to item 2.2 & 2.3.

图 (1) CM-VII型隔振器

Fig (1) CM-VII type vibration isolator

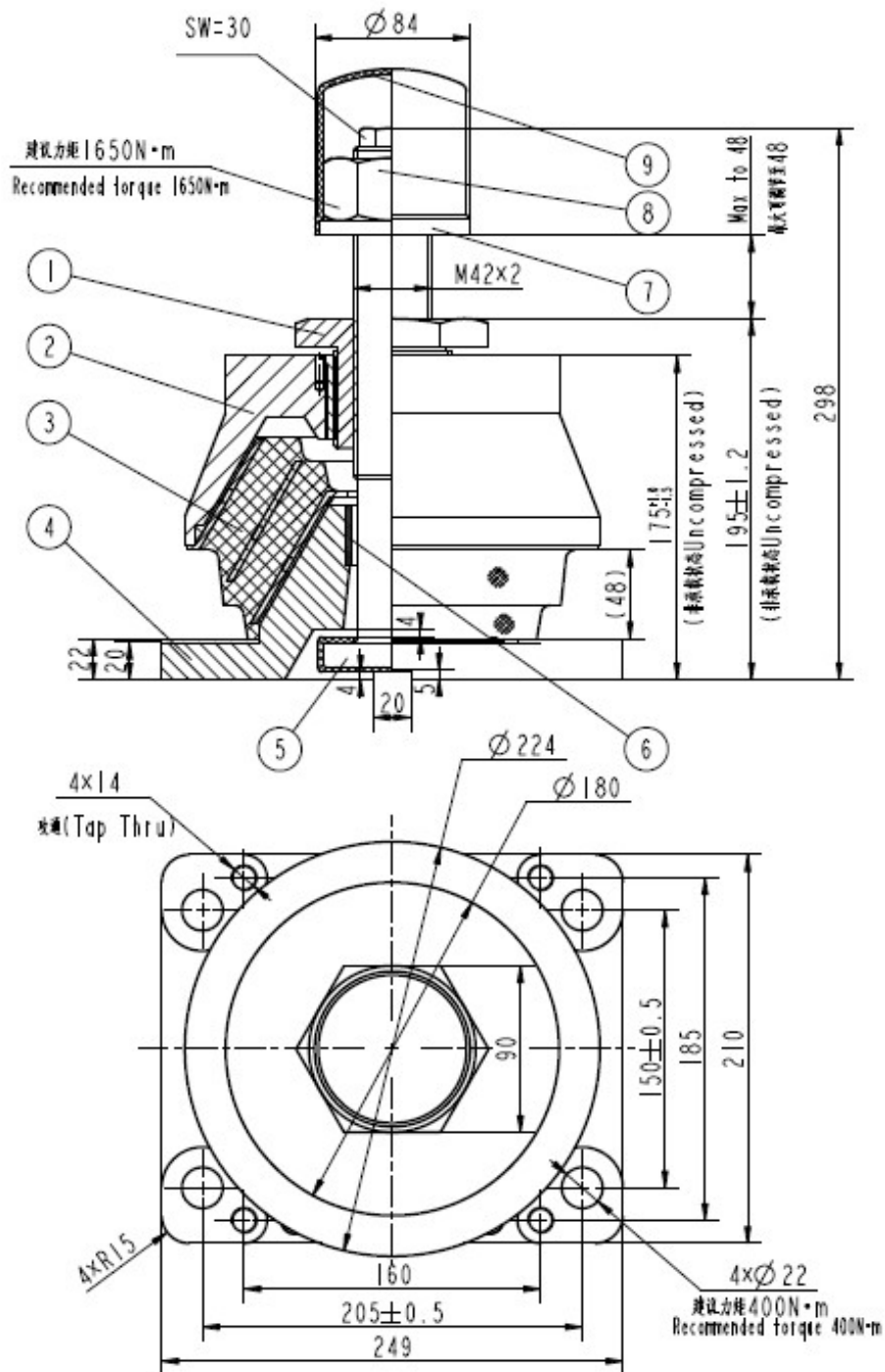

- 1、调节螺母 Adjusting Nut; 2、上座板 Top Casting; 3、锥形减振圈 Resilient Mounting;
4、下座板 Base Casting; 5、缓冲限位螺栓 Internal Buffer; 6、橡胶圈 Rubber Coil;
7、垫圈 Washers; 8、螺母 Nut; 9、保护帽 Protective cap。